

How does Classify work?

Classify combines several technologies that form an AI unit specially designed for the detection of material properties of high variance objects at high speed. The system consists of a recording unit housing four cameras connected to a local processing device. Objects can be classified in a few milliseconds in free-fall. Our special neural network architecture makes this kind of image data processing possible. It consists of an adaptive sensor system based on infrared sensor grids to capture images of the objects in the optimal position. If required, the Classify box can also be equipped with special cameras such as UV or IR sensitive sensors to detect special contaminants such as organic residues. The model is able to locate and classify defects on multimodal images, such as multispectral images. It detects defects such as stains and holes and is able to distinguish different kinds of them and can process up to four objects per second.

Our Service

The DESION Inspection Systems reliably and precisely recognize properties of complex objects and different materials in your production. We develop custom systems for your specific use case following industrial standards.

Seperation

Detection

Sorting

On request we master the whole process within our network.

DESION GMBH
CAMERA BASED INSPECTION SYSTEMS
FOR COMPLEX OBJECTS

Our portfolio includes:

- Adaptation of our products to your production
- Consulting and feasibility studies
- Custom software and hardware development

CONTACT

DESION GmbH
Bad Nauheimer Str. 4
64289 Darmstadt, Germany
www.desion.de

Dirk Siegmund
CEO
+49 (0) 6151 73475-757
dirk.siegmund@desion.de

CLASSIFLY

DETECTION OF MATERIAL
PROPERTIES AT HIGH SPEED

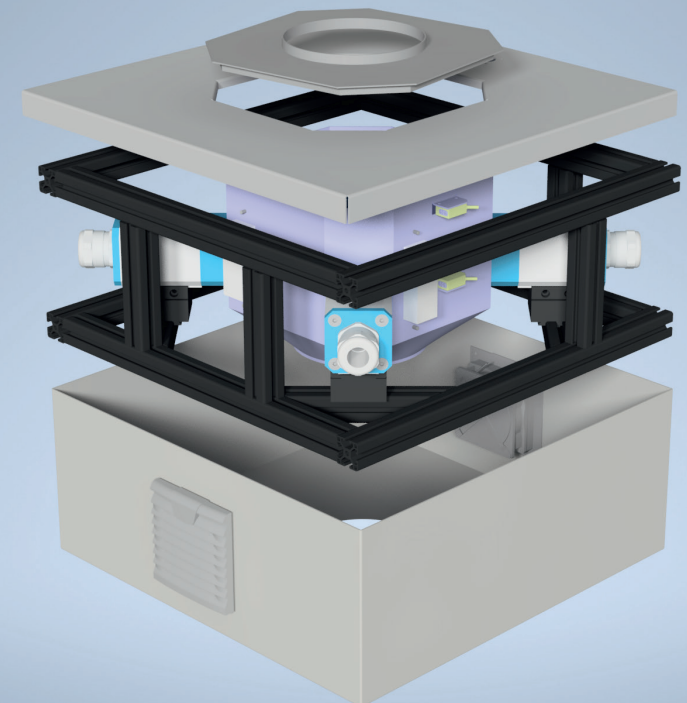

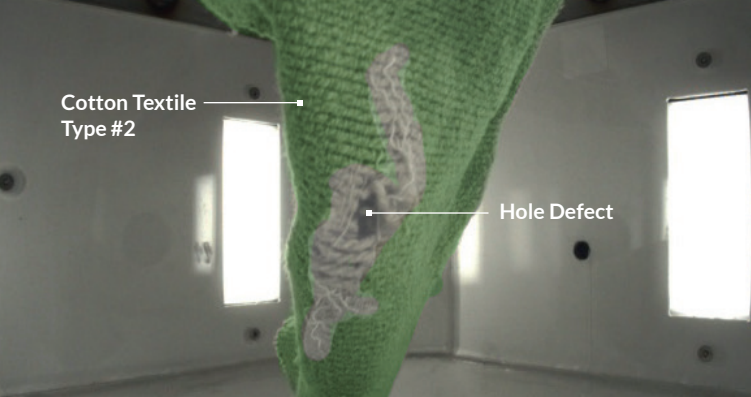

The DESION Classify Detection System

The sorting of deformable objects like fabrics, plastics or viscous liquids according to defects or product categories plays an important role in many applications. Many processes benefit from automation like sorting of cleaned textiles, textile recycling and returns handling. Sorting of textiles according to defects or quality standards is not only cost efficient but also important for the sustainable use of resources.

What does our Technology accomplish?

One of the biggest problems with the automatic sorting and quality assurance of deformable textiles is to examine the entire object at once, because deformability goes along with a high probability of covering (occluding) individual areas. Therefore, and because an orderly, flat placement of the textiles is very time-consuming, we propose examining the textiles in free-fall with the here presented Classify Recording Unit.

Our free-fall test systems were developed for quick quality control and sorting of objects. Even during free-fall, our models are able to recognize material properties and defects as well as their positions in less than 100 ms. In addition, our technology makes it possible to determine 3D information of the objects on the fly, i.e. their size. As soon as the object leaves the test box these results are available for further processing.

The Classify Recording Unit

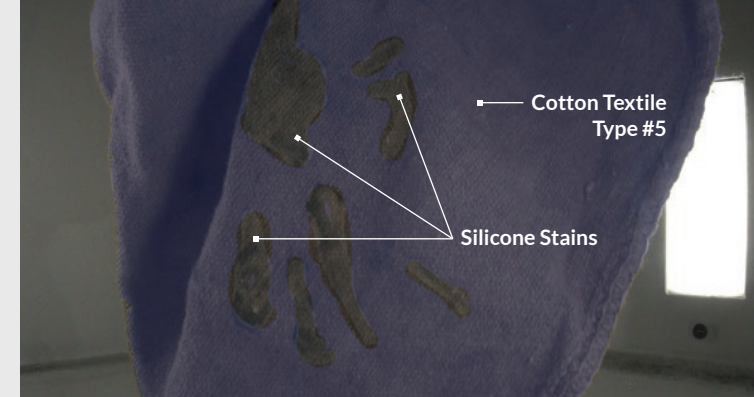
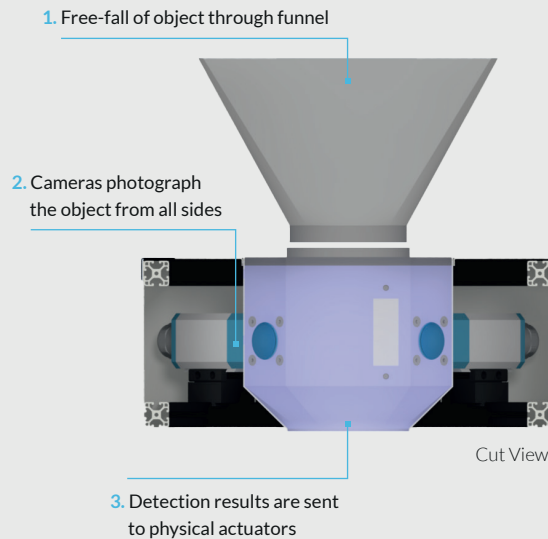
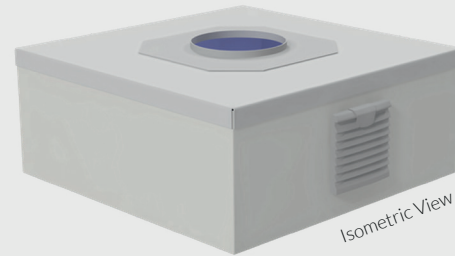

How to integrate Classify in your Environment?

Objects can be fed mechanically via conveyor belts, grippers or manually by hand. Depending on the location and application, sorting out can be done e.g. via flaps underneath the box or by conveyor belts. Classify can be controlled via PLC using common protocols (e.g. Profinet, Modbus TCP). DESION will gladly create an overall concept that is tailored to your application.

What can Classify be applied for?

There are lots of potential applications beside the inspection of textiles. Classify was successfully tested with the following objects:

- Textiles, cloths
- Building materials
- Agricultural goods

What can it detect?

Following characteristics can be detected by our system:

- Holes, cracks
- Different kind of stains
- Material types (e.g. different fibers, weaving)
- Clothing types
- Color deviation
- Organic contamination
- Consistency